

E1 – Total drive efficiency within all details



While some competitors address the challenge of gearbox efficiency only, Schindler focuses on total drive efficiency, namely efficiency in the gearbox as well as the motor.

Choose our Premium Power Package for optimized environmental performance

By opting for our Premium Power Package, you'll be able to lower your utility bills. And by consuming less power, you'll also reduce the environmental impact (greenhouse gas emissions) of the power plants which generate your power.

Maintenance by Schindler

Choose Schindler to service and maintain your escalator using Schindler-manufactured spare parts, and you can be confident it will stay in excellent working order.



In commercial applications such as shopping malls, periods with low or no passenger traffic are common.

MICONIC F 5 power management system comes as standard

Schindler has been using microprocessor-controlled power management systems for over 20 years, significantly longer than some competitors. Our MICONIC F controller is now in its fifth generation and comes as a standard feature.

ECOLINE power management packages, including customizable operating mode

Schindler's goal is to optimize energy efficiency without compromising passenger flow. Depending on the power management package, power consumption can be reduced by up to 36% relative to continuous operation.

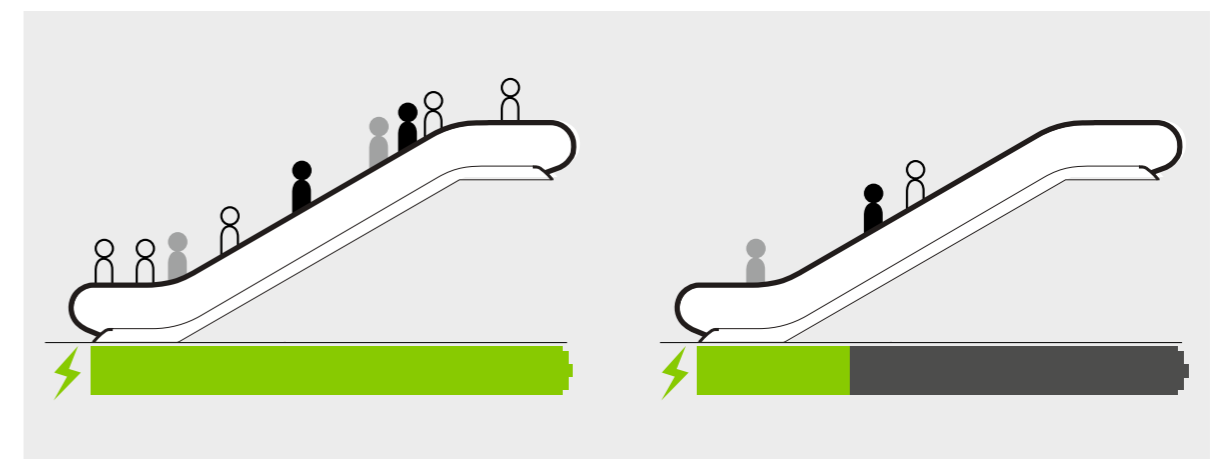
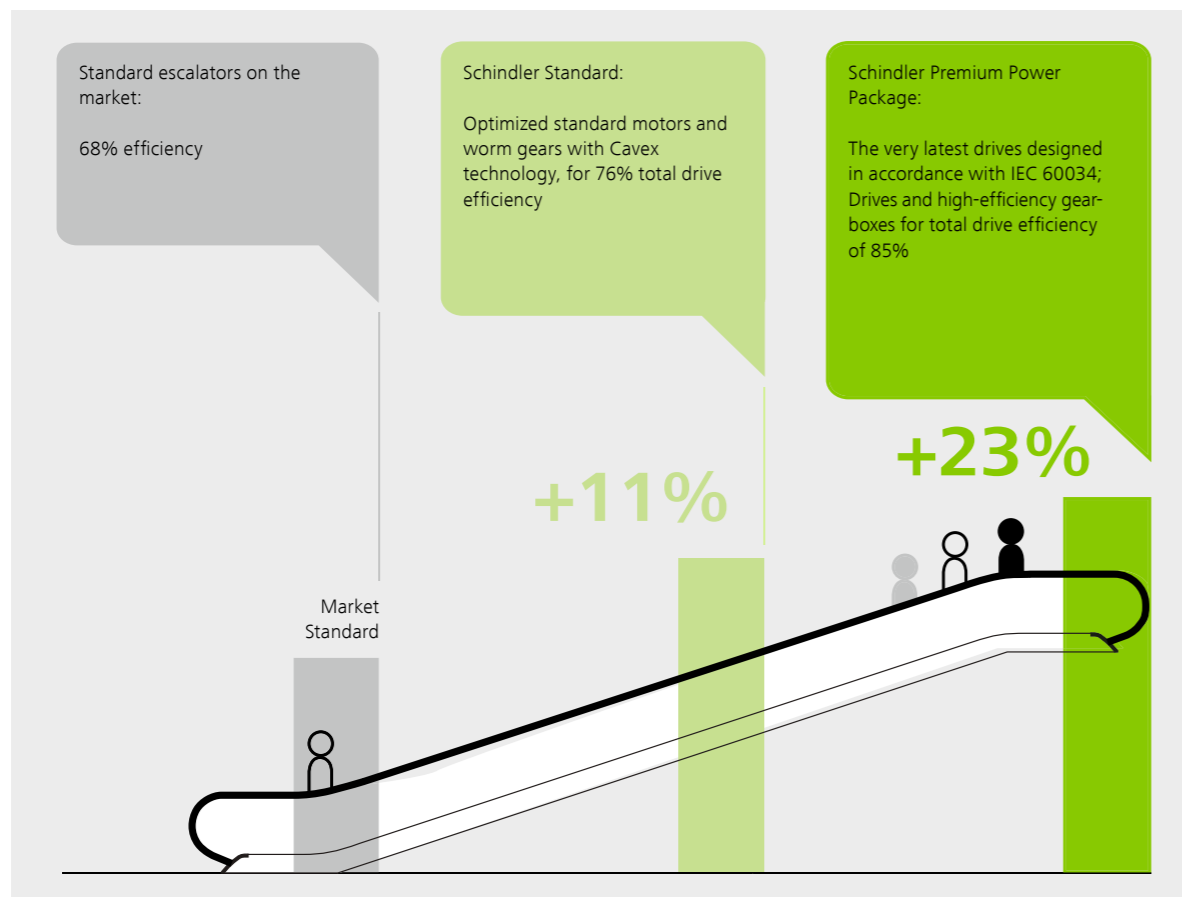

Remarkable power-saving due to Schindler's smart power management

When vision meets discipline

Schindler partners with Solar Impulse

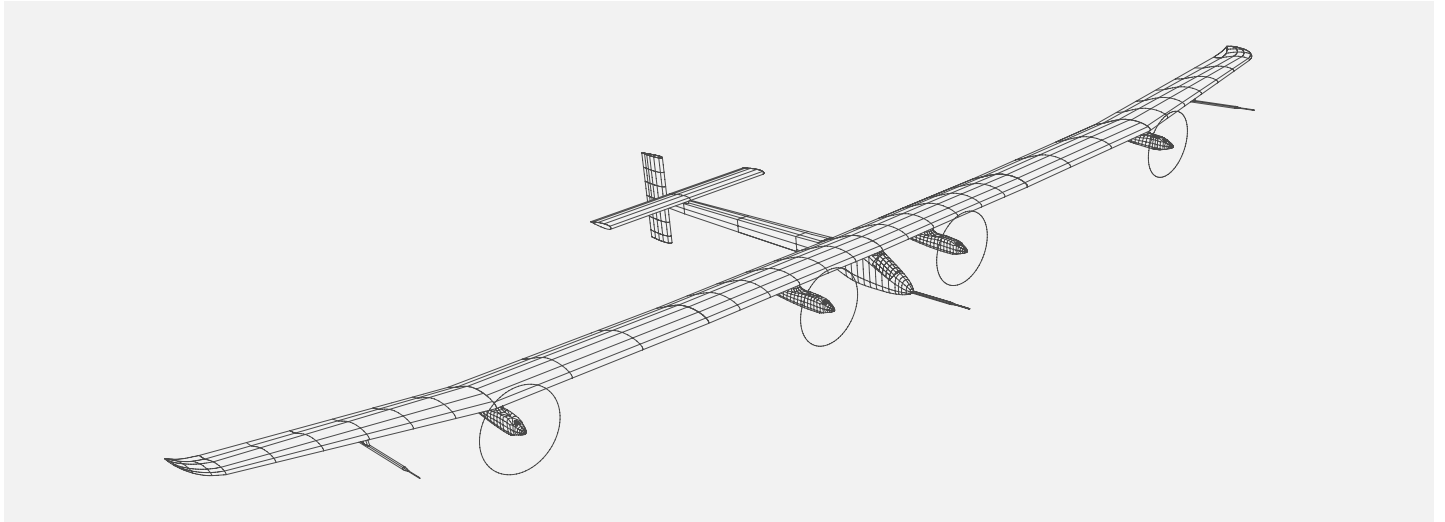

Schindler has delivered many industry benchmarks in innovation, including a state of the art 2-channel safety circuit, short-pallet moving walks, and the very latest development, a comprehensive energy-efficiency concept for escalators and moving walks.

Schindler is supporting the Solar Impulse, a project to fly a zero-fuel airplane around the world propelled by solar energy only.

By embedding its engineers in this challenge, Schindler remains at the cutting edge of technology for clean and sustainable mobility.

www.solarimpulse.com

Read more on Schindler's sustainability efforts:

www.schindler.com

Schindler Management Ltd.
Global Business New Installations
Zugerstrasse 13
6030 Ebikon
Switzerland

www.schindler.com